

T1/T3 is for dual analog supply.
T2/T4 is for single digital supply.

Each transformer placeholder
has two different footprints.

If series resistors R1–R3 are not used,
replace with 0-ohm resistors or wires.

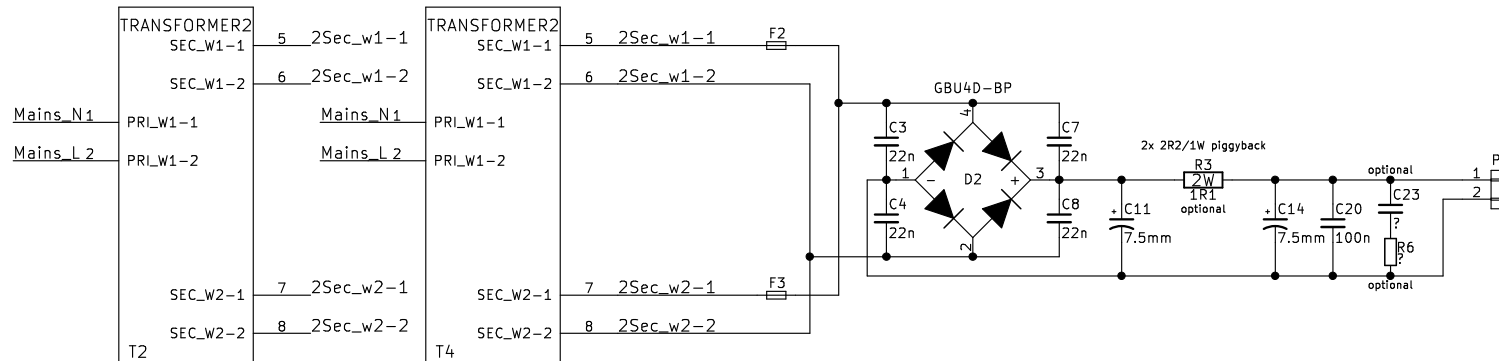

Tomi Nihtilä

Sheet: /
File: DualTrafoBoard_v11A.sch

Title: DualTrafoBoard

Size: A4 Date: 2016-04-17

KiCad E.D.A. kicad 4.0.1-stable

Rev: v1.1A

Id: 1/1