

Root sheet

Sheet: Input Selector

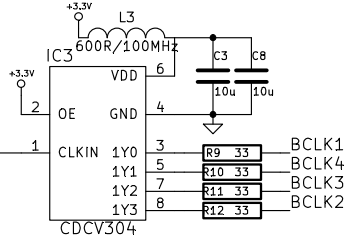

Sheet: SPDIF Output Ch1&2

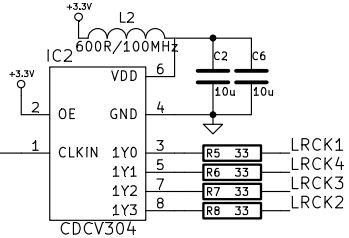
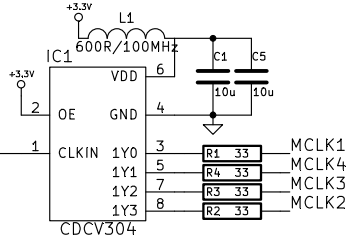
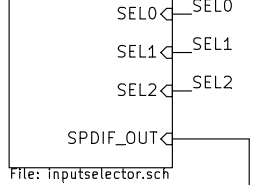
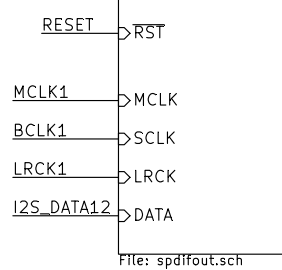

Sheet: SPDIF Output Ch3&4

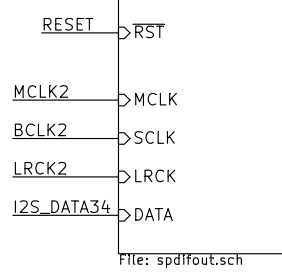

Sheet: SPDIF Output Ch5&6

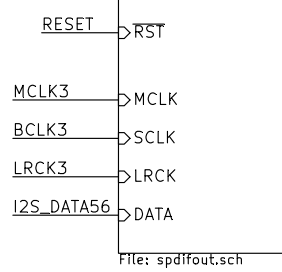

Sheet: SPDIF Output Ch7&8

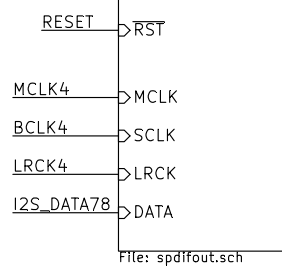

PSU components are assembled based on needs.

With proper input voltage, U3 and its components can be omitted and shorted with R41. Then choose appropriate filter capacitor. If U3 is used R41 must be omitted.

Supply for DSP can be chosen with L21 or L23.

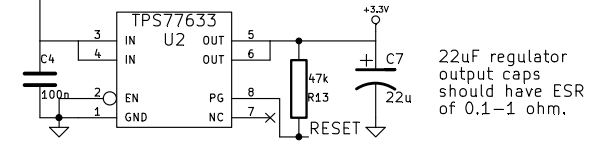
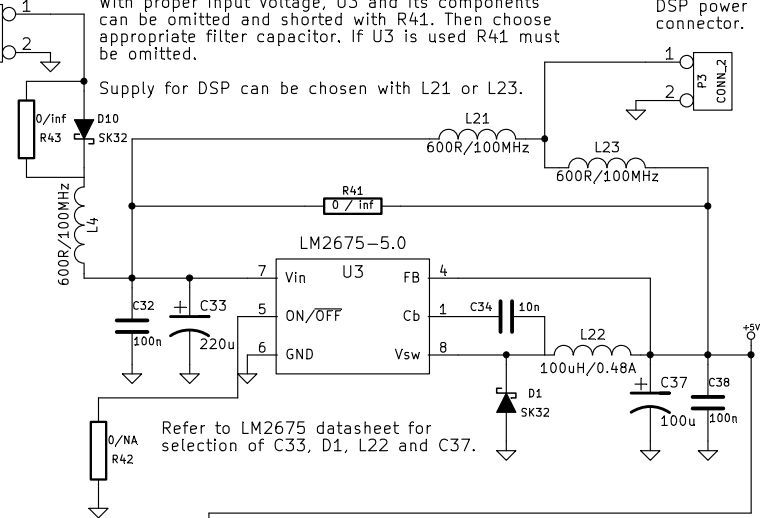

Sheet: MCU

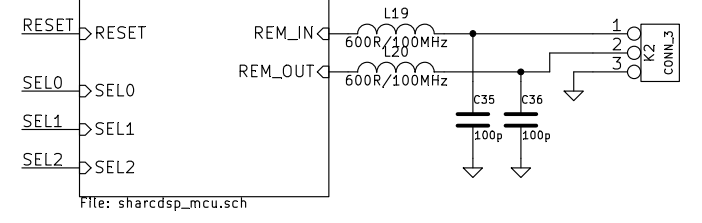

Schematics contains numerous ferrite beads. Despite their filtering feature they are also used as bridges and can be replaced by 0-ohm resistors.

Tomi Nihtilä		
File: sharcdsp.sch		
Sheet: /		
Title: SharCDSP		
Size: A4	Date: 30 nov 2014	Rev: Rev 1
KiCad E.D.A. eschema (2013-07-07 BZR 4022)-stable		Id: 1/7

SPDIF output

Note: There is no indication of non-audio or invalid data in SPDIF-signal since DSP doesn't give any signaling about errors etc.

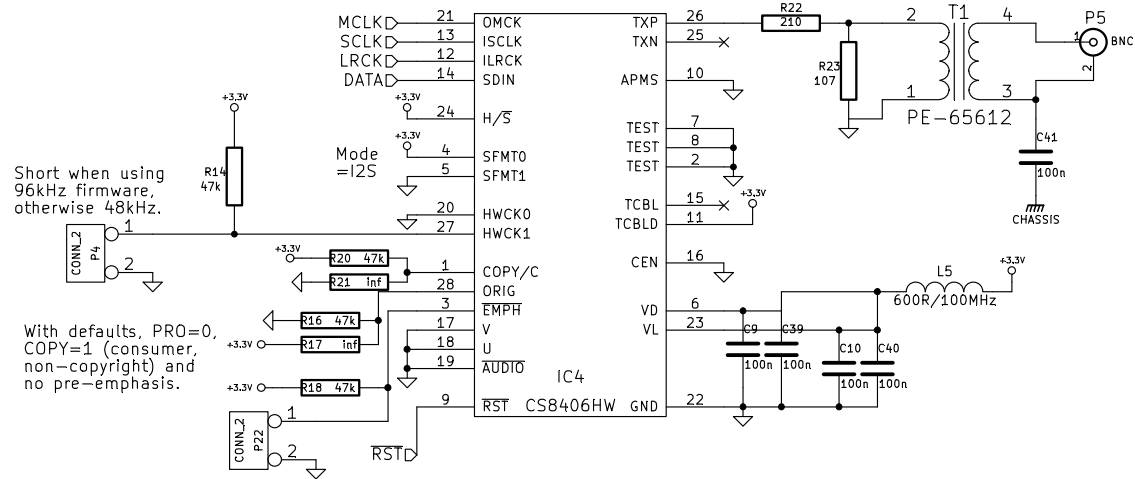

Tomi Nihtilä		
File: spdifout.sch		
Sheet: /SPDIF Output Ch1&2/		
Title: SharcDSP		
Size: A4	Date: 30 nov 2014	Rev: Rev 1
KiCad E.D.A. eeschema (2013-07-07 BZR 4022)-stable		Id: 2/7

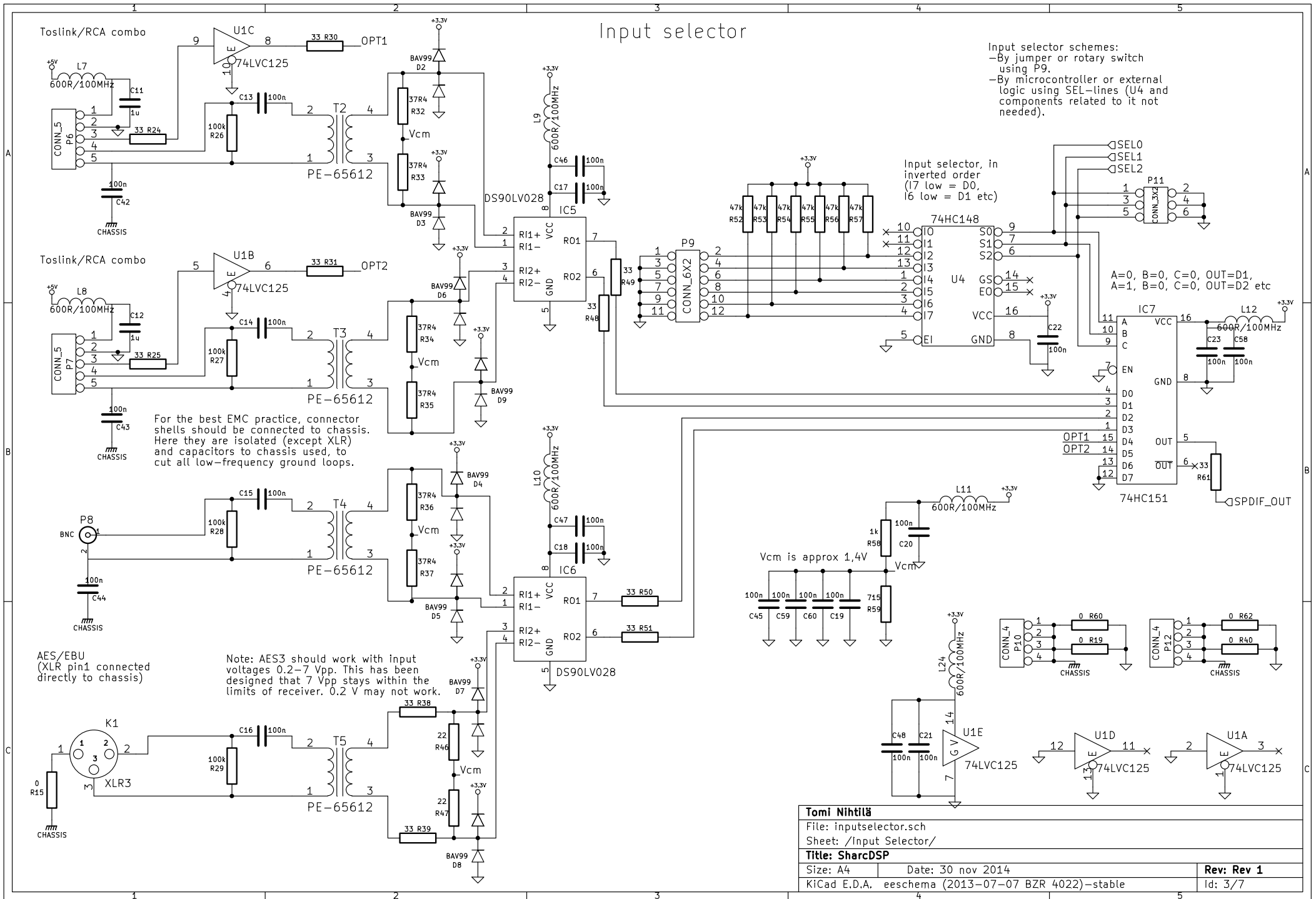

SPDIF output

Note: There is no indication of non-audio or invalid data in SPDIF-signal since DSP doesn't give any signaling about errors etc.

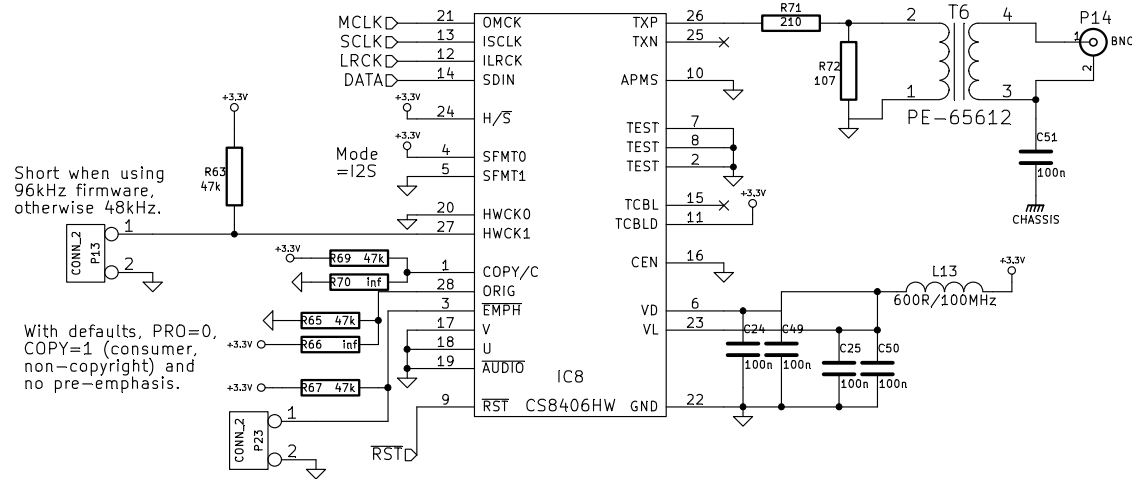

Tomi Nihtilä		
File: spdifout.sch		
Sheet: /SPDIF Output Ch3&4/		
Title: SharcDSP		
Size: A4	Date: 30 nov 2014	Rev: Rev 1
KiCad E.D.A. eeschema (2013-07-07 BZR 4022)-stable		Id: 4/7

SPDIF output

Note: There is no indication of non-audio or invalid data in SPDIF-signal since DSP doesn't give any signaling about errors etc.

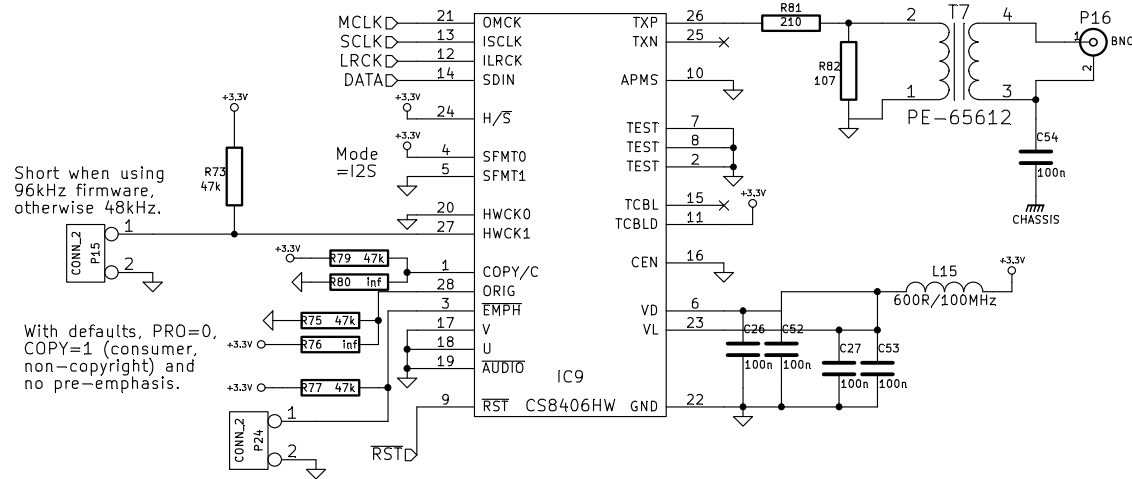

Tomi Nihtilä		
File: spdifout.sch		
Sheet: /SPDIF Output Ch5&6/		
Title: SharcDSP		
Size: A4	Date: 30 nov 2014	Rev: Rev 1
KiCad E.D.A. eeschema (2013-07-07 BZR 4022)-stable		Id: 5/7

SPDIF output

Note: There is no indication of non-audio or invalid data in SPDIF-signal since DSP doesn't give any signaling about errors etc.

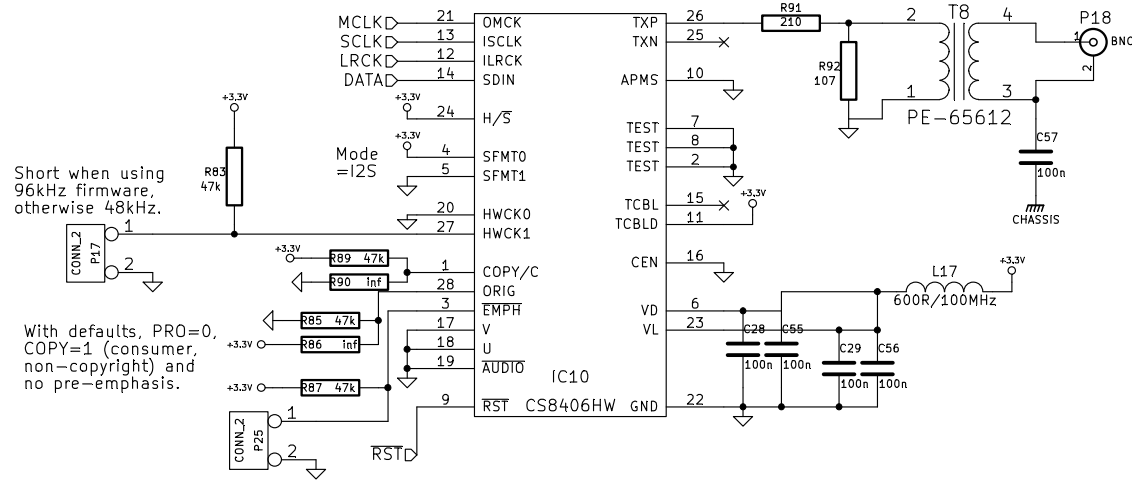

Tomi Nihtilä		
File: spdifout.sch		
Sheet: /SPDIF Output Ch7&8/		
Title: SharcDSP		
Size: A4	Date: 30 nov 2014	Rev: Rev 1
KiCad E.D.A. eeschema (2013-07-07 BZR 4022)-stable		Id: 6/7

MCU

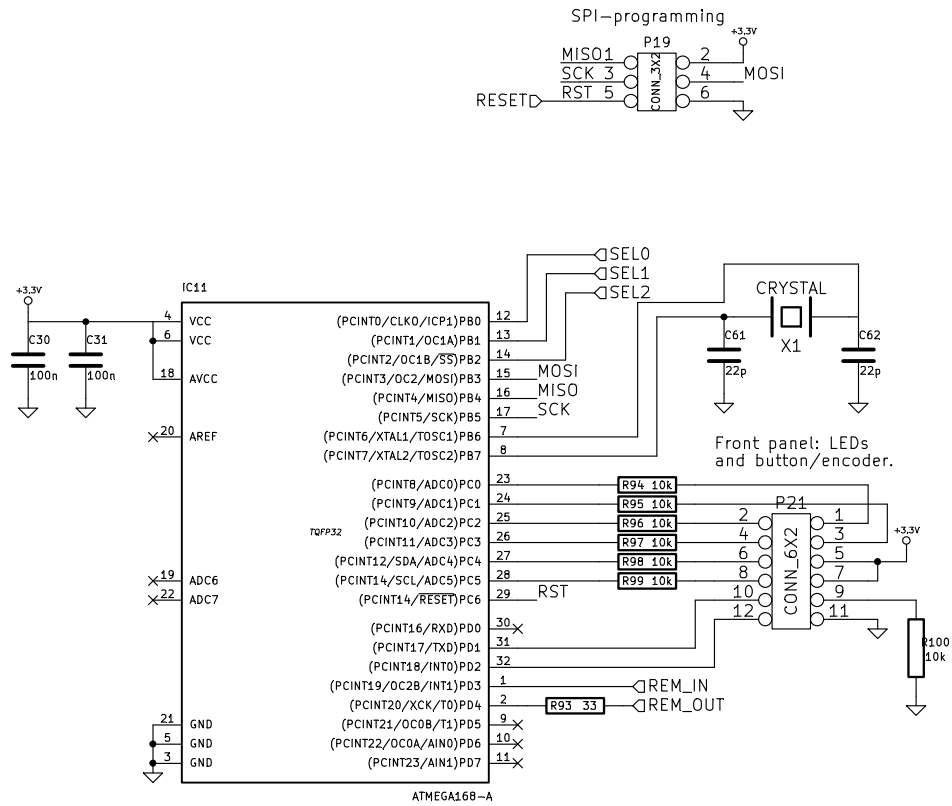

Tomi Nihtilä		
File: sharcdsp_mcu.sch		
Sheet: /MCU/		
Title: SharCDSP		
Size: A4	Date: 30 nov 2014	Rev: Rev 1
KiCad E.D.A. eschema (2013-07-07 BZR 4022)-stable		Id: 7/7